

ARTS AND CRAFTS



SELECTING CRAFTS

Crafts can be a fun part of your camping experience. With input from the girls you will be able to pick craft projects that are right for your troop.

The camp environment can pose some crafting challenges, so think projects through. Remember that wind will blow paper, sand and dust can ruin paint jobs, and small items that are dropped in the grass or dirt may be difficult to find.

Choose crafts that are age appropriate.

Be flexible.

Promote creativity and individuality. A craft that must look a certain way can frustrate girls.

Plan ahead – test the project if possible.

Have all materials ready.

Don't rush.

Have something for early finishers to do.

Show the girls how. Help when needed, but let it be the girls' work.

Remember that you should not pick flowers or leaves without permission from the site managers. If necessary, bring these items with you.

Memory books, scrapbooks, and journals are wonderful projects to make while camping. Experiment with different ways to decorate their covers. Let each girl create her own cover.

SIT-UPON

(Fun to make, fun to use!)
(Good project to make before camping trip)



You will need:

Sewing Machine

Old Jeans

Polyester Fiberfill

Something for a belt such as rope, bandanas or leather strip (we used a old lace scarf)

Cut the legs off an old pair of jeans about 1" from crotch. Trim sides and inner legs to shape like photo above. Turn inside out and stitch up bottom.

Turn right side out. Stitch along top of waistband. You may have to skip over belt loops and glue those areas.

Open zipper and fill with polyester fiberfill. Close zipper. Thread your "belt" through the loops. Tie in front. Feed back through the front loops and tie at top for a handle.

SCRAPBOOKS

You will need:

Cardboard, 11x17 inches

Assorted photos, drawings, school papers

For cord: twine, ribbon, or chenille stems

Construction paper, 11x17 inches

Hole punch and glue stick

For spine: stick, 12 inch ruler, or paintbrush

Set cardboard on table and stack the desired number of 11x17 inch pages of construction paper on top. For cover, glue together a collage of photos, drawings, or other designs. Place cover on top of pages.

Punch two holes about 6 inches apart through all layers.

Pull cord up from under cardboard, through pages, and cover. Loop the cords over the spine (stick, ruler, or paintbrush), thread back down through the same hole, and tie ends together. Repeat for the second hole.

For other covers, try rubber stamping, a nature drawing, spatter painting, rubbings, etc.

KEY CHAIN SCRAPBOOK

You will need:

Metal key ring

Small scrap of cardboard

1 inch piece of hook and loop fastener (Velcro)

Self-adhesive vinyl, such as Con-Tact brand

3/8x9½ inch piece of ribbon

Cut 2x3¼ inch piece of cardboard for cover. Adult: With scissors point, make two scores about ¼ inch apart at center.

Cut vinyl about ½ inch larger than cover. Peel off backing, adhere to cover, and fold the excess vinyl over cover edge, sticking it to the inside of cover.

Cut a 4½-inch piece of ribbon and thread it through key ring. Fold ribbon in half and glue along inside spine.

Glue 5-inch ribbon to inside back cover.

For pages, cut a 7/8-x15 inch strip of construction paper. Accordion-fold every 1½ inches. Glue first page to inside front cover and last page to inside back cover. Attach hook and loop fastener to ribbon end and outside back cover so they line up to hold book together. Glue photos, drawings, etc. to pages.

PHOTO DIORAMA

You will need:

5¼ inch expandable file
Craft glue and tape

Construction paper
Assortment of photos from same season and location
(enlargements work better)

Cut a window in the front of file.

Cut out photographed people and tape the largest one in front. Attach the smaller photos of people to the backside of window. Tape a scenic photo to the inside back of file.

Cut out construction paper into shapes of sun, clouds, etc. Also, at the top right corner of the front panel, you can cut out to reveal a cloud and blue sky.

SUN PRINTS

You will need:

Ammonia
Pebbles or other items (to keep paper from touching)
Box to keep paper in
Ozalid paper (buy at blue printing outlets or stationery stores)

Large cans or containers with lids
Objects to photograph
Sunshine

Do this activity in a well-ventilated area. Talk to the girls about safety precautions when using ammonia. Adults should do the developing when doing this activity with younger girls.

Experiment with other developing systems. Remember it is the fumes that do the developing.

DEVELOPING IN A LARGE CAN OR CONTAINER

You will need:

Several large cans or containers with lids
Ammonia
Pebbles or other items (to keep paper from touching)

Make sure that the can or container is large enough to accommodate the paper. Put the pebbles or items into the bottom of the can. Add ammonia but don't cover the pebbles. The ammonia fumes will actually develop the sun print.

Choose objects for your sun print. Arrange objects on surface making sure they will fit on paper. Take paper out of the box, keeping it out of the sun. Quickly arrange items on the paper while casting a shadow over the paper with your body. Put objects on the yellow side of the paper. Let the sun shine on the paper. As soon as the yellow around the edges of the objects disappear, quickly put paper in the developing chamber and close lid. Before your print is developed, take extra care to keep it out of the sun. You may want to put it in a dark bag or in a folder to avoid losing your design. Leave in the chamber about 1½ minutes. Remove from can. Experiment with exposure time to sun and developing time in chamber.

DEVELOPING OVER AN OPEN PAN

You will need:

Large pan or tub slightly larger than the largest print you want to develop
Ammonia

Pour the ammonia into the pan. Hold the sun print over the ammonia until developed. Do not immerse paper into the ammonia.

RAIN PAINTING

(This activity, from the “if you can’t beat ‘em, join ‘em” department, makes the most of rainy weather.)

You will need:

Paper plate (Chinet or other uncoated plate)
Food coloring
White crayon

Sprinkle a few drops of food coloring on a paper plate.
Have child don her rain gear and walk outdoors with the plate for about a minute.
For a batik effect, try drawing a white crayon design on the plate before adding the food coloring.

NATURE PINS

You will need:

Clear Contact paper	Size 2 Safety pins
Metal nail file	Flowers and leaves gathered (with permission, of course!)
Clear coat or sealer	

Cut two 2” circles of Contact paper. Select flowers and/or leaves to press on to one of the circles. Cover with the second piece of Contact paper. Trim.
Spray safety pins with clear coat to keep them from tarnishing.
Use the point of metal nail file to bend open the loop at the base of the safety pin. Use the pin to poke a hole in the top of your nature design. Push it down the front shank of the pin, around the loop and on to the back shank of the pin.

ROCK NECKLACE

(Use a rock collected from a special place or during a special outing.)

You will need:

Rock
Hemp or cording
Low temp glue gun or tacky glue

Cut a 1-yard piece of hemp. Attach to the back of the rock with glue. Wrap hemp several times around rock, securing as necessary with glue. Tie ends together to form a necklace.

Variation: Use a seashell instead of a rock.

MOLD A SAND CASTLE

If your kids seem to truck home enough sand after a day at the shore to build another beach, here's a good use for it. Make your candles during the day, then set them aglow at twilight. A word of caution: Your help with this project not only adds to the bonding experience, but it is also crucial for safety.

You will need:

Large heat-proof mixing bowl	Sand, enough to nearly fill the bowl
Empty 1 lb. coffee can	Store-bought paraffin or old candle stubs
Store-bought wicking	Thin wood dowel or stick

Fill the bowl $\frac{3}{4}$ full with slightly damp sand and ask the child to dig a mold about the size of her fist. Using your hands, bend one side of the coffee can rim to form a spout.

Fill the can halfway with paraffin, then set it in a saucepan that's $\frac{1}{4}$ filled with water. (Never place the can directly on the burner or fire.)

Melt the wax over very low heat; when it has melted, turn off the heat.

Cut the wicking to 6-8 inches longer than your mold is deep.

Rest your dowel across the bowl's top and tie one end of the wick around it. Press the other end into the bottom of the mold.

Now it's the adult's job to carefully pour the wax into the mold until it reaches about 1 inch from the top.

When the candle is cool, remove it from the mold, brush off any excess sand, and trim the wick.

FOOTPRINTS IN THE SAND

On beach vacations, sand seems to end up everywhere especially between the toes. This simple plaster-casting project lets your child capture that sandy barefoot feeling – and a record of her feet.

You will need:

Plaster of Paris	Small bucket
Freshwater	4 inch lengths of string or wire (for hangers, if desired)
Bring sand if necessary	

Choose a site to cast your molds – the moist, hard packed sand near (but not too near) the water's edge works best.

Have your child firmly press both feet into the sand. The prints should be about $\frac{1}{2}$ inch to 2 inches deep. If your child can't press down that hard, she can use her finger to dig down into the print, following its shape. Mix up the plaster according to the directions on the package so that it has a thick, creamy consistency. Pour the wet plaster gently into the prints.

If you want to make hangers, tie a knot about a $\frac{1}{2}$ inch in from each end of your pieces of string or wire. As the plaster begins to harden, push the knotted ends into the plaster and let dry.

After 20 – 25 minutes, gently dig the footprints out of the molds and brush away any excess sand. Set sole side up in the sun (away from the rising tide) for about an hour to let harden.

OJO DE DIOS - GOD'S EYE

The symbolism of God's Eye goes back many thousands of years and was found in many cultures. On the back of the United States dollar bill appears a God's Eye (above the pyramid).

The primitive Indians of Mexico expressed a symbolic God's Eye by weaving varied-colored yarns around a frame of small sticks. Mother North Water, a goddess of Huichol (We'chol) Indians, took the form of a servant, or a fish, with spots on her shoulder. The eye or "sikuli" is symbolic of these spots with the power to see and understand unknown things. The God's Eye was then laid upon the altar so

that this goddess could look upon the supplications as this tribe asked for a good corn crop. This symbol predates their Christianization, though it is now used as part of the design for their Christian cross. It was often placed in a child's hair, hung on the wall in the home, or tied to the end of an arrow to protect and bless.

Add a pin for a great swap, add a loop for an interesting ornament or add some cord to make a necklace.

You will need:

Multi-colored yarn Mini craft sticks Low temp hot glue gun or Tacky Glue

Glue two mini craft sticks together forming an "X". Glue ends of the yarn to the middle where your sticks cross. Begin by wrapping the yarn over and around one leg of one craft stick, then over and around the next leg. Continue until the craft sticks are covered. Glue and trim.

NATIVE AMERICAN DANCE STICK

(Recommended for ages 7 and up.)

You will need:

Stick (measuring ½"x24") Yarn Faux Fur Scrap
2 Jingle Bells 12" suede lace 4 pony beads
2 feathers Tacky Glue Scissors

Cut a piece of fur 1'x2'. Wrap it around the end of the stick. Use tacky glue to secure it. Spread a little glue at the end near fur. Wrap yarn tightly around stick adding more glue as needed. Cover about 5" of the stick changing the color if desired.

Tie suede lace near the bottom of the yarn wrap. Lace through bells, knot again. String 2 pony beads onto each end. Tie off and trim. Slip feather ends up through beads with a little glue to secure.

YARN DREAM CATCHER

(Recommended for ages 7 and up.)

You will need:

Yarn in two or more colors White glue
Scissors Hole punch

Lid from round ½ gallon ice cream container or large coffee can

Cut yarn into 3-yard lengths. Stiffen one end of each piece with white glue. Feed one piece of yarn through a hole in the rim. Pull through to other end and tie into place. Weave randomly back and forth through rim. Tie off, glue, and trim. Repeat with one or more pieces of yarn.

Make three tassels by wrapping yarn several times around four fingers. Leave a few inches of yarn on one end. Remove from fingers and pinch together at that end. Use another piece of yarn to wrap pinched strands together. Tie off. Cut open loops on other side. Push long piece of yarn through a hole punched in the rim. Glue and trim.

NATURAL DYES

Berries, stems, barks, flowers, leaves, roots, etc. can be used to make dyes that will color cloth or yarn. Use ripe berries, flowers, and leaves at full bloom; bark collected in spring or early summer; roots collected in early fall.

You will need:

Plants or parts of plants	Something to chop on
Large kettle (enamel is good) and cover	Strainer
Cloth to be dyed	1 oz. alum (obtainable from drugstore or grocery store)
Wooden stick for stirring	½ cup vinegar or 1 tbsp. salt
¼ oz. washing soda or ¼ oz. cream of tartar, depending on type of cloth to be dyed (see below)	

To make the dye:

Chop plants into small pieces and cover with water. Soak overnight.
Boil for an hour or more, until color is much deeper than the color you want.
Strain to remove all pieces of plants.

To prepare the cloth to be dyed:

Wash and rinse the cloth in soap and water.
Add 1 oz. alum to a gallon of water. Also add ¼ oz. washing soda if cloth to be dyed is made of a vegetable fiber (cotton, linen, rayon). If the cloth is made of an animal fiber (silk, wool) add ¼ oz. cream of tartar.
Put the cloth in this solution and boil it for an hour. Rinse and dry it.

To dye the cloth:

Use a kettle large enough to hold the dye and cloth to be dyed. Add enough water that the dye will cover the cloth.
Bring liquid to a boil and add cloth. Stir with wooden stick.
Lift the cloth on the stick so that you can see light through it. The color will be close to the color your cloth will be when it dries. You may have to boil the cloth in the dye from half hour to one hour to get the shade you want.
“Set” the dye so it will not wash out. To do this, add ½ cup of vinegar or 1 tbsp. of salt to the liquid in the kettle and boil for 15 minutes.
Remove the cloth from the dye. Rinse it in cool water and hang it in the shade to dry.

These plants make these colors:

Goldenrod stalk and flowers	yellow
Sumac Leaves	yellow brown
Onion Skins	red or yellow
Beets	red violet
Dandelion Roots	magenta
Rhubarb Leaves	light green
Spinach Leaves	green
Blackberries	blue
Sunflower Seeds	blue
Hickory Bark	brown
Walnut Hulls	brown

PLEASE NOTE: Do not pick. Bring from home or get camp ranger’s permission to pick.

FRIENDSHIP STICK

This little stick means "Friendship" of a very special kind. A friend is great and hard to find. This stick is a symbol of friendship. It is curved to fit the curve of the earth, symbolizing friendship that can grow, as do the forests.

The green circle at the bottom of the stick is for faith in God and one another. It is first on the stick because it is the basis for a happy and meaningful life. Faith in yourself, your fellow persons, and your Girl Scout Law and Promise.

The next four circles represent the races of the world – red, yellow, black, and white. They stand close together indicating that all people are equal. Every person is capable of becoming a loyal and good friend.

The green belt of hope is above the races. It is hope for the future – that people everywhere will try to overcome any differences in opinion and human failings. Both faith and hope are green – a combination of hues and emotional feelings we cannot adequately describe. The four races bounded by faith and hope can produce unity – working together for the good of all...of the world. The cross shows four paths leading toward a central goal – signifying the attachment of this unity.

The cross shows how the four races can come together and work for peace.

The smiling face is the result of friendships based on faith and unity. The brown and blue eyes represent the races of the world. The smiling face is a reminder of those persons whom we call friends. To be greeted by the smiling face of a friend is one of the greatest joys we can experience.

The Girl Scout green crowns the face, indicating loyalty to Girl Scouts and the friendships developed therein.

On the back of the Friendship Stick, a green cross is carefully placed opposite the four races to show that peace and charity can exist among all people.

A Friendship Stick must be carved and painted by the giver, thus showing the time, thought, and effort that go into a meaningful friendship.

Use Button Pins in slit on back; glue to hold.

Coat with 2-3 coats of clear nail polish or shellac.

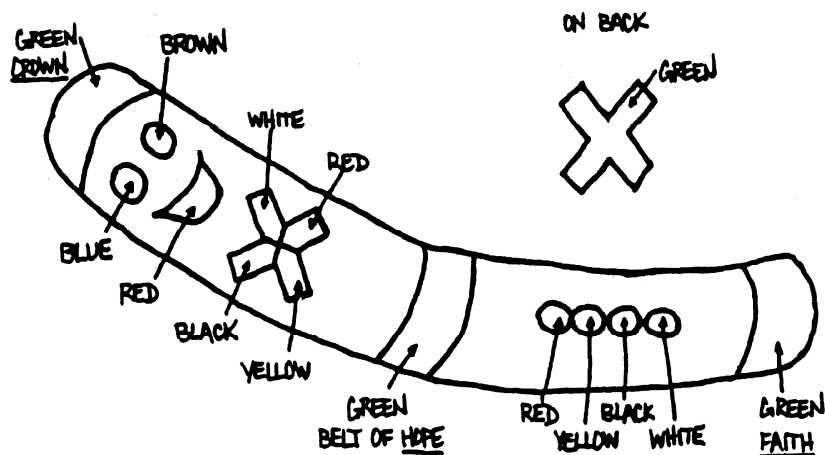

FRIENDSHIP KNOT

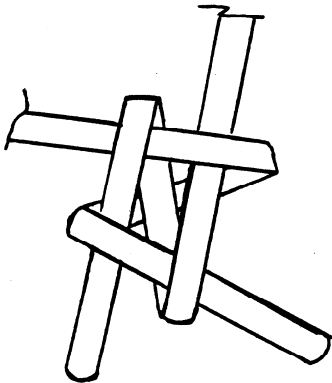
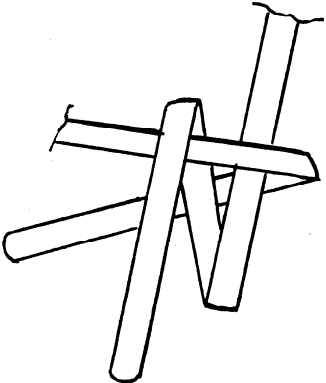
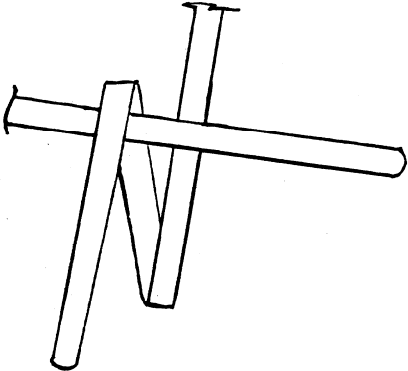
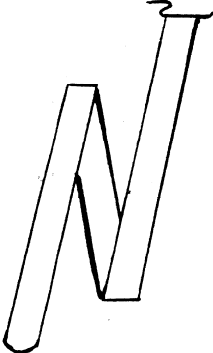
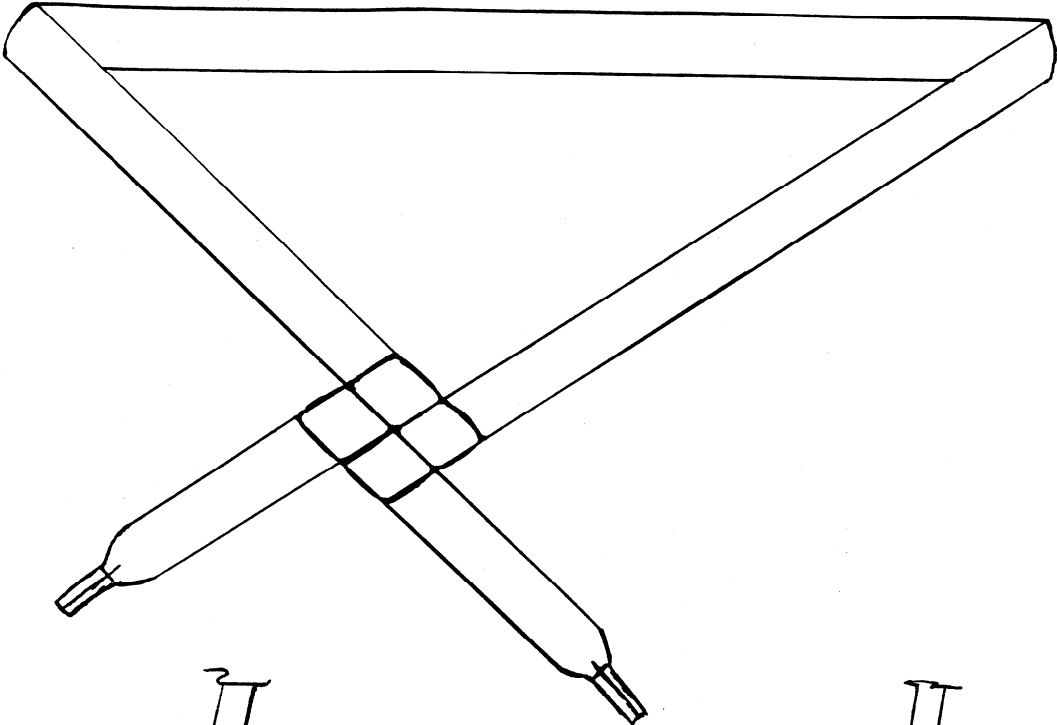

BRAIDED SUEDE FRIENDSHIP BRACELET

What do you admire most about your friend: Is she generous? ... loyal ... kind?

Make this special gift to let them know how you feel by choosing your bead colors from the list below.

Generous	Orange
Loyal	Blue
Kind	Pink
Responsible	Green
Honest	Red
Cheerful	Yellow



You will need: 8 feet Suede lacing 3 pony beads

Instructions:

Cut lacing into three 2' pieces and two 6" pieces. Use one 6" piece to tie together the three 2' pieces. Make the knot about 4" from the end as shown. Braid together the three 2' pieces for about 1". Slide a pony bead onto the middle lace and continue braiding for another inch. Add another pony bead and continue for another 1" then adding the last pony bead. Finish by braiding for another inch and use the remaining 6" piece of suede to tie off. Trim ends.

DAISY FRIENDSHIP BRACELET

You will need:

2' of string or cord 4 green pony beads 6 white pony beads
1 yellow pony bead white glue

Instructions:

1. Coat ends of cord with white glue. Let dry. String 6 white pony beads and slide to center of cord.
2. Loop cord around and feed through bead 1 again. Tighten.
3. String one yellow pony bead and position it in the center of the flower. Feed cord back through bead. Tighten.
4. Tie a knot on both sides of daisy. String a green bead on to each side and tie another knot to hold bead in place.
5. Repeat step four, knotting 2" from first knot. Trim to size. Bracelet ties onto wrist.

HEMP FRIENDSHIP BRACELET

You will need:

6 yards of hemp

miscellaneous beads

masking tape

Preparing your cord:

Cut hemp into two 3-yard lengths. Fold both pieces 18" from the end. Gather the folded strands together. You now have two 18" strands and two 7½' strands. Tie all together into a knot 4" from the fold. Secure by taping to tabletop at fold. You could also use a clipboard or slip loop made by folding around a chair leg. Pull both 18" strands taut and tape down ends. Wrap each long strand around a small piece of cardboard to make them easier to work with.

Making the knots:

Cross strand 1 over strands 2 and 3 and under strand 4.

Bring strand 4 under strands 2 and 3, then up through the loop created by strand 1. Tighten.

Cross strand 1 over strands 2 and 3 and under strand 4.

Bring strand 4 under strands 2 and 3, then up through the loop created by strand 1. Tighten.

Making the knots:

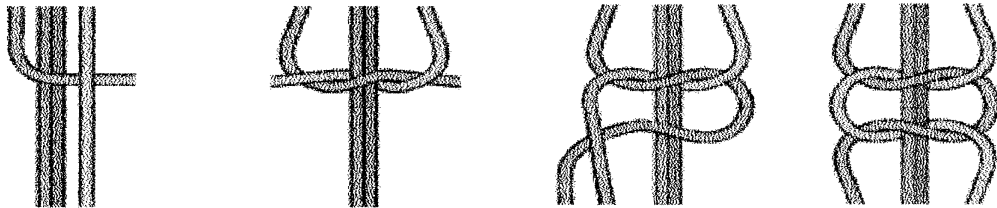

Adding beads:

Beads can be added at any point on the bracelet. You can string them on one, two or all four strands.

Finishing:

When you reach the desired length, make a knot to match the other end. Remove tape. Trim ends, leaving enough to tie on wrist. Make a knot on each strand end to keep from fraying, adding a bead if desired.

FRIENDSHIP PENS

Make them for yourself or swap 'em with your friends!

Why not use your scout colors or your favorite colors.

(Ages 8 and up.)

You will need:

Ball Point pen Multi-color yarn

Tacky glue or low tack glue gun

Beads (optional)

Instructions:

Using as little glue as possible, place a very thin bead of glue near the tip of the pen and up about 1" on to the barrel. Starting near the tip, wrap yarn tightly around pen without leaving any gaps. Add more glue as you go. You can change yarn colors but it is much easier to use multicolor yarn. When you reach the end, trim and secure with a little dab of glue. Cut three 12" pieces of yarn. Knot the three pieces together near one end. Braid and end with another knot. Glue on pen end. Add additional braids if desired. You can also add pony beads, alphabet beads, or number beads (decorate with your troop number).

TIE DYE MARKER SOCKS

You will need:

Permanent broad tip markers

white or light socks

rubber bands

Rubbing alcohol

spray bottle

Loop rubber bands tightly around socks about 1½" apart. Press marker tip on socks leaving some areas white. Spray rubbing alcohol on socks. This will blend the colors. Set aside at least two hours to let color spread. Remove rubber bands. Iron, using a damp press cloth to set the color. Dry overnight. Wash in cold, gentle cycle; dry in dryer.

You could also use this method on t-shirt, pillow cases, etc.